

Valio BS/WS HD - assembly instructions:

List of parts:

- 5 driving wheels
- 1 chair base
- 1 pneumatic jack
- 6 screws M6x35 mm
- 3 screws M8x20 mm
- 3 spring washers M8
- 1 seat with Synchro Plus mechanism
- 2 armrests (left/right)
- 1 headrest
- 1 backrest with a connector
- 2 Allen wrenches for M6 and M8 (shape"L") screws



GROSPOL Sp. z o.o.
Ostródzka 53
03-289 Warszawa
www.grospol.pl

VALIO HD CHAIR HANDLING

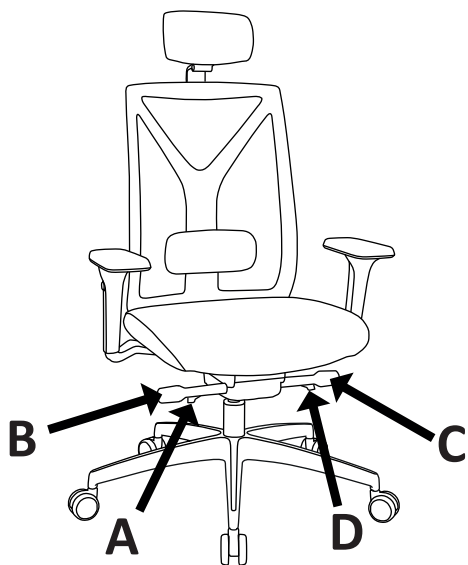

A - seat height adjustment. Pulling the lever upwards raises the seat. Releasing the lever to the initial position will lock the selected height.

B - backrest tilt force adjustment. Unscrewing the screw (-) reduces the backrest resistance. Tightening the screw (+) increases the backrest resistance.

C - Adjustment of the backrest and seat tilt angle. Turn the knob back to release the movement of the mechanism following the user's movement in the chair. Turning the knob forwards locks the back and seat in a selected position.

D - adjustment of seat depth. Pulling the lever up releases the seat depth lock and allows you to adjust it to the user's preferences. Releasing the lever to its original position locks the chosen position.

Additional adjustment of the chair:

- lumbar support depth adjustment, using the black knob located in the lumbar profile.
- Height of the armrests: while sitting in the chair, pressing the button on the armrest allows to adjust the height of the armrest (up and down).
- length adjustment (front/back), position angle (inwards/outwards)
- Backrest height adjustment by gripping the backrest with both hands and moving it (up and down). It is possible to set 1 of 5 available levels and the width (left/right) of the armrest.
- the height and angle of the headrest can be adjusted by moving it directly in the indicated direction.

ASSEMBLY:

1. Press the wheels into the chair base

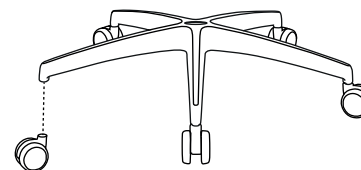

2. Insert the pneumatic lift into the hole in the chair base.

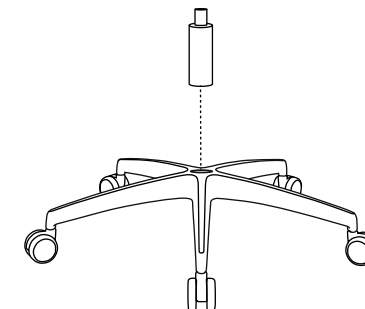

3. Using the Allen key, screw the armrests into the seat.

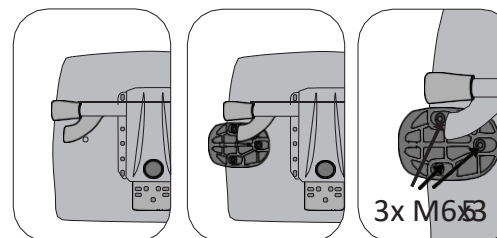

4. Using the Allen key, screw the backrest to the mechanism with three M8x20 mm screws and 3 M8 washers

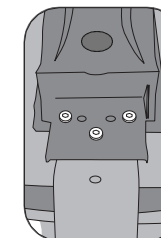

5. Place the seat on the pneumatic lift cone. Tighten the cone connection by exerting pressure the seat once.

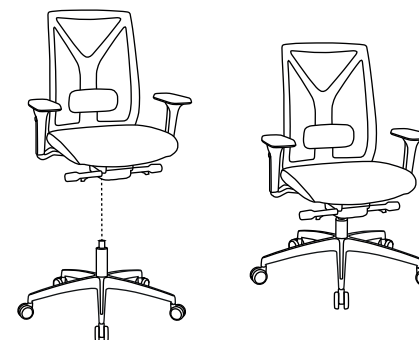

6. Slide the headrest into the screwed holder



GROSPOL attaches a VAT invoice to each shipment, which is a proof of purchase of goods, as well as a guarantee document in case of a complaint. On request, we also issue a separate guarantee card.



GUARANTEE CARD

NAME AND TYPE OF PRODUCT:

DATE OF SALE:

PURCHASER:

1. GROSPOL products are under guarantee for 36 months from the date of sale. The basis of the guarantee is a proof of purchase: a receipt, a VAT invoice with the date of purchase. This Guarantee does not have to be signed.
2. In case of a defect, the user should submit a written complaint to the fax number: 22 781 78 94 or by e-mail to: reklamacje@grospol.com.pl
3. Product defects revealed during the guarantee period will be removed free of charge within 14 business days from the date of complaint acceptance.
4. If the removal of the defect is not possible or would involve excessive costs, the manufacturer may replace the product with a new one.
5. The warranty does not cover:
 - natural wear of the product,
 - mechanical damage to the product,
 - defects caused by improper use (see: Rules of proper use of the product),
 - product defects after any alterations and changes without the manufacturer's consent.
6. The guarantee for consumer goods does not exclude, limit or suspend the rights of the buyer resulting from the non-compliance of the goods with the sales contract.
7. Matters not regulated by these terms and conditions of guarantee are regulated by the contents of the Civil Code, the Act on Providing Electronic Services and the Act on Consumer Rights Protection.

Stamp and signature of the seller

Principles of proper use of the product

OPERATION

1. The products should be used according to their intended use.
2. All GROSPOL products are intended for use in dry and indoor spaces.
3. The products should be used and stored away from direct fire sources.
4. The products should not be exposed to prolonged sunlight, as the colours may change gradually.
5. The products must not be exposed to direct heat sources (distance from heat sources not less than 1 m).
6. Proper use of GROSPOL products will ensure their long and failure-free operation.
7. Please **DO NOT USE** your whole body weight supporting yourself on the armrests when getting up from the chair.

Armchairs and chairs are designed for use by one person only. You are not allowed to:

- sit down on them, several people at the same time,
- stand on their seats,
- transport heavy objects on them,
- sit on armrests.

MAINTENANCE AND CLEANING

Upholstery

Use commercially available upholstery care products for cleaning. It is recommended that you test the effect on a piece of upholstery beforehand.

Chrome-plated and varnished coatings

For cleaning chrome-plated and varnished surfaces we recommend products designed for cleaning such surfaces, which do not contain abrasives. Floors with coated products varnished and chrome-plated should not be cleaned with aggressive agents affecting varnish and chrome.

Plastic elements

Use generally available non-scratching plastic cleaners

Caution! Damages resulting from non-compliance with the above recommendations are not grounds for a complaint.